



Doctoring systems

GOOD DOCTORING IS ESSENTIAL FOR EFFICIENT PAPERMAKING!

The proper design and application of a doctoring system can improve the performance of your paper machine.

BONETTI doctoring systems, are custom designed to meet the deflection and natural frequency requirements for a particular machine width, speed and roll diameter.

Engineering at BONETTI is supported by the most advanced software available on the market. We perform finite element analysis (FEA) to accurately model our products to determine structural integrity, performance and reliability, as well as predict structural failures.

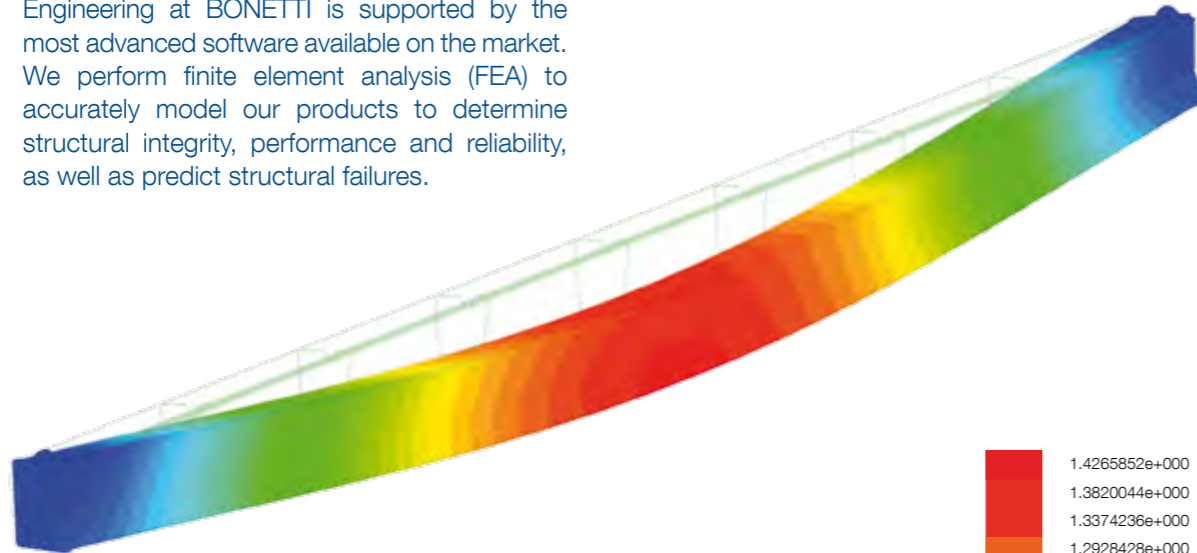

BONETTI beams are stress relieved and machined in the intended working position, to remove the natural deflection present in the structure after fabrication.

BONETTI troubleshooting team is available for field machine reports, maintenance and improvements to increase doctoring performance and blade life, as well as for installation supervisions.

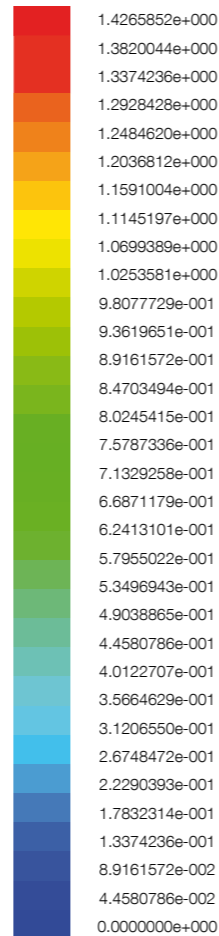
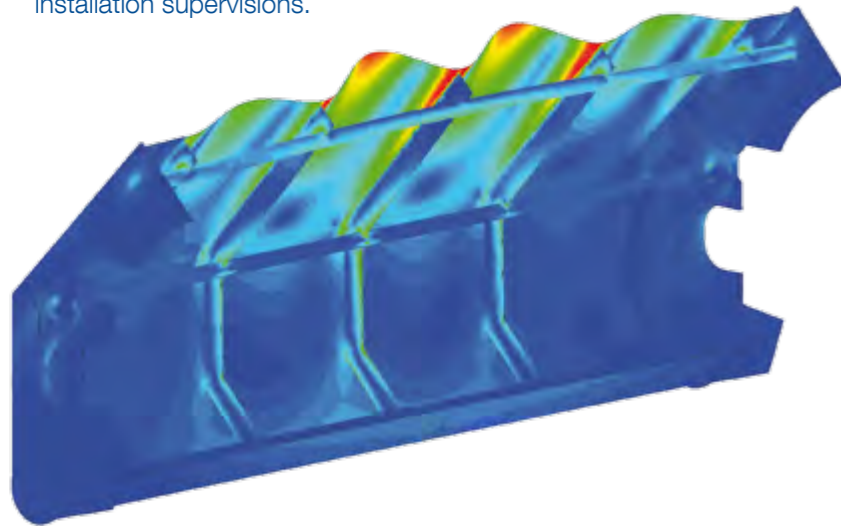

Contact us TODAY, and we will work out the best doctoring solution for your needs!

BONFIFLEX SUPER

Heavy duty self conforming tube loaded blade holder fabricated in stainless steel AISI 316L. Top plate in carbon composite material available upon request.



BONFLEX

Light duty fingerless self conforming tube loaded blade holder fabricated in stainless steel AISI 316L.



REVERSE BONFIFLEX SUPER

Heavy duty self conforming tube loaded blade holder fabricated in stainless steel AISI 316L, for grooved or drilled rolls dewatering applications.



REVERSE BONFLEX

Light duty fingerless self conforming tube loaded blade holder fabricated in stainless steel AISI 316L, for grooved or drilled rolls dewatering applications.

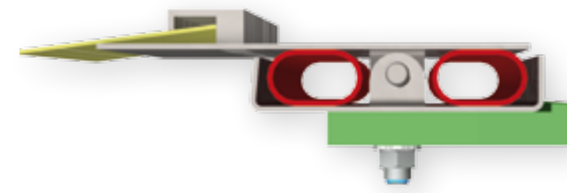

BONFIRM K35

Rigid blade holder fabricated in stainless steel AISI 316L or in mild phosphatized steel.

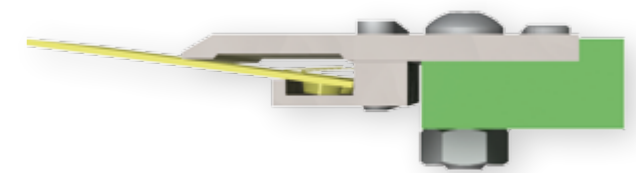

BONFIRM SUPER K35

Rigid blade holder fabricated in stainless steel AISI 316L. Specially engineered for dryer section applications. The special design allows easy blade replacement thanks to its self-cleaning feature.

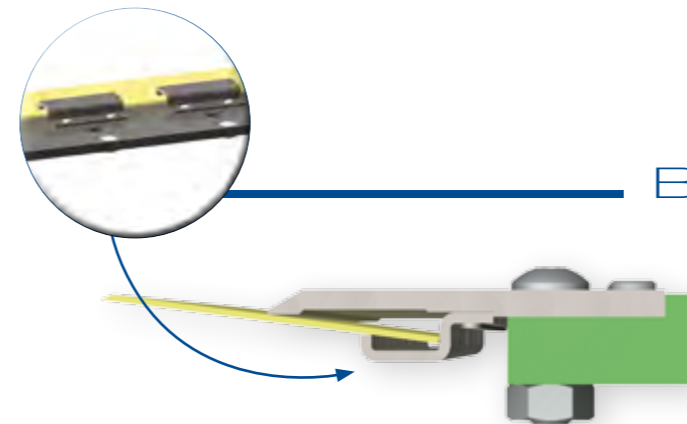

Contact us TODAY, and we will work out the best doctoring solution for your needs!

Tray design doctors for wire rolls

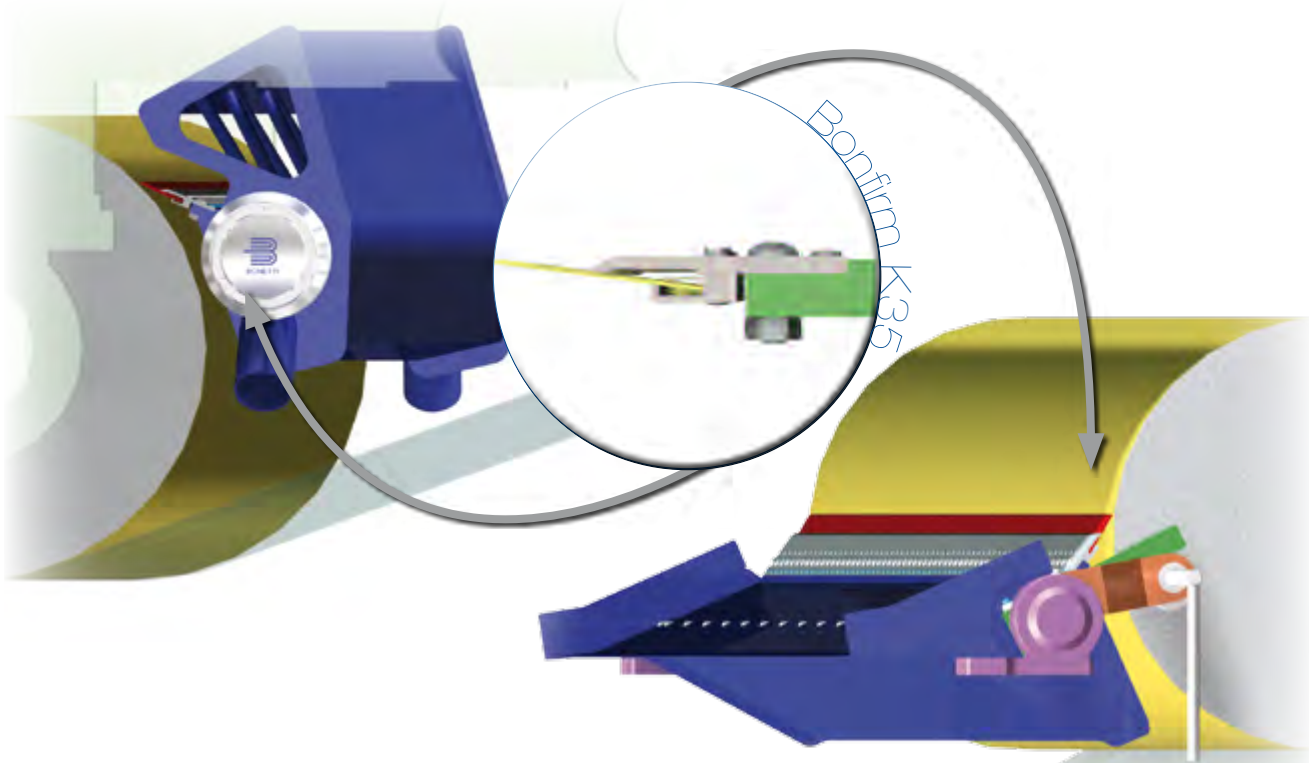

Box design doctors for wire rolls

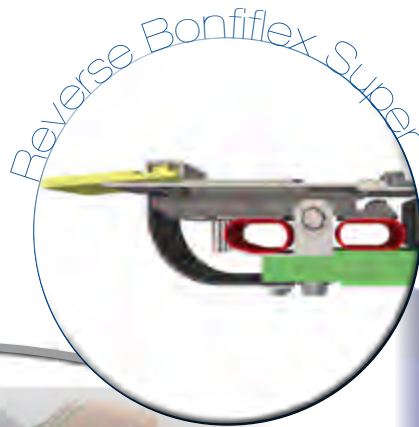

Save-all with integrated doctors for couch rolls

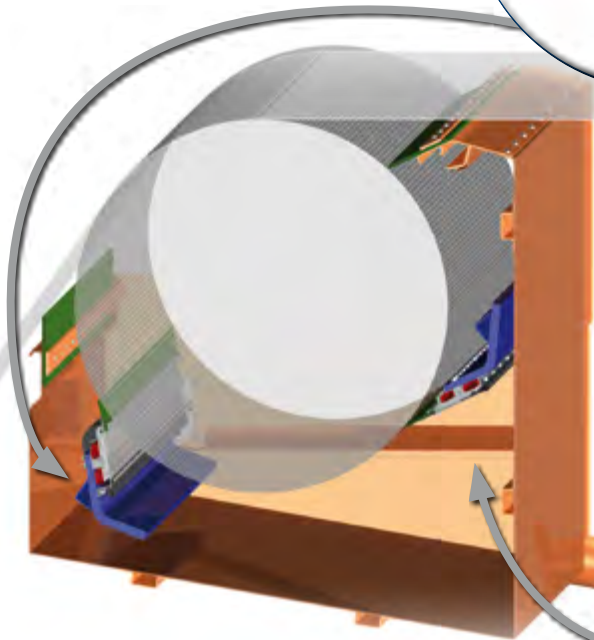

Bontwin for couch rolls

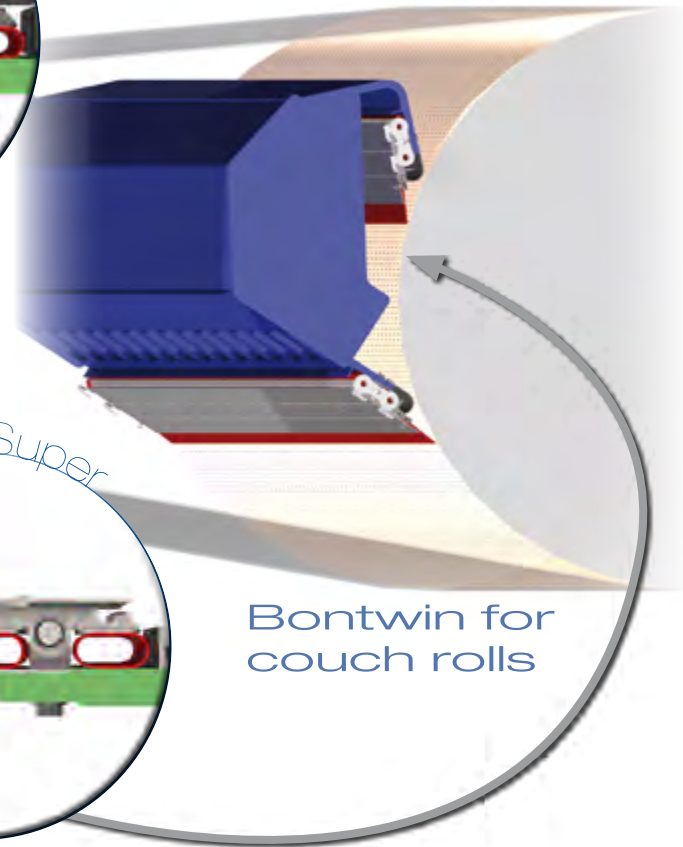

Bontwin for press applications

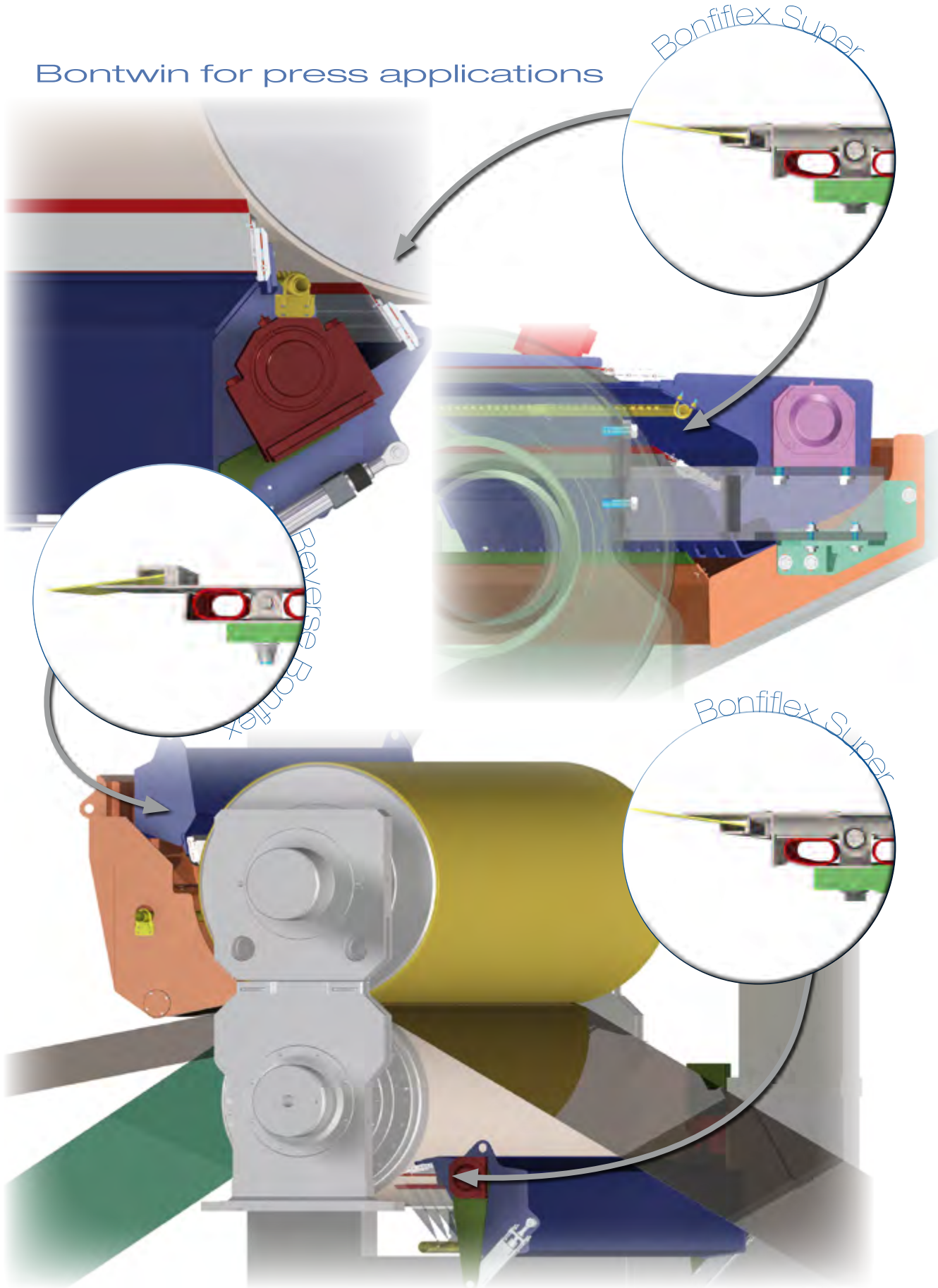

Complete doctors for shoe presses

Complete doctors
for dryer sections
with BONFIRM K35
holders

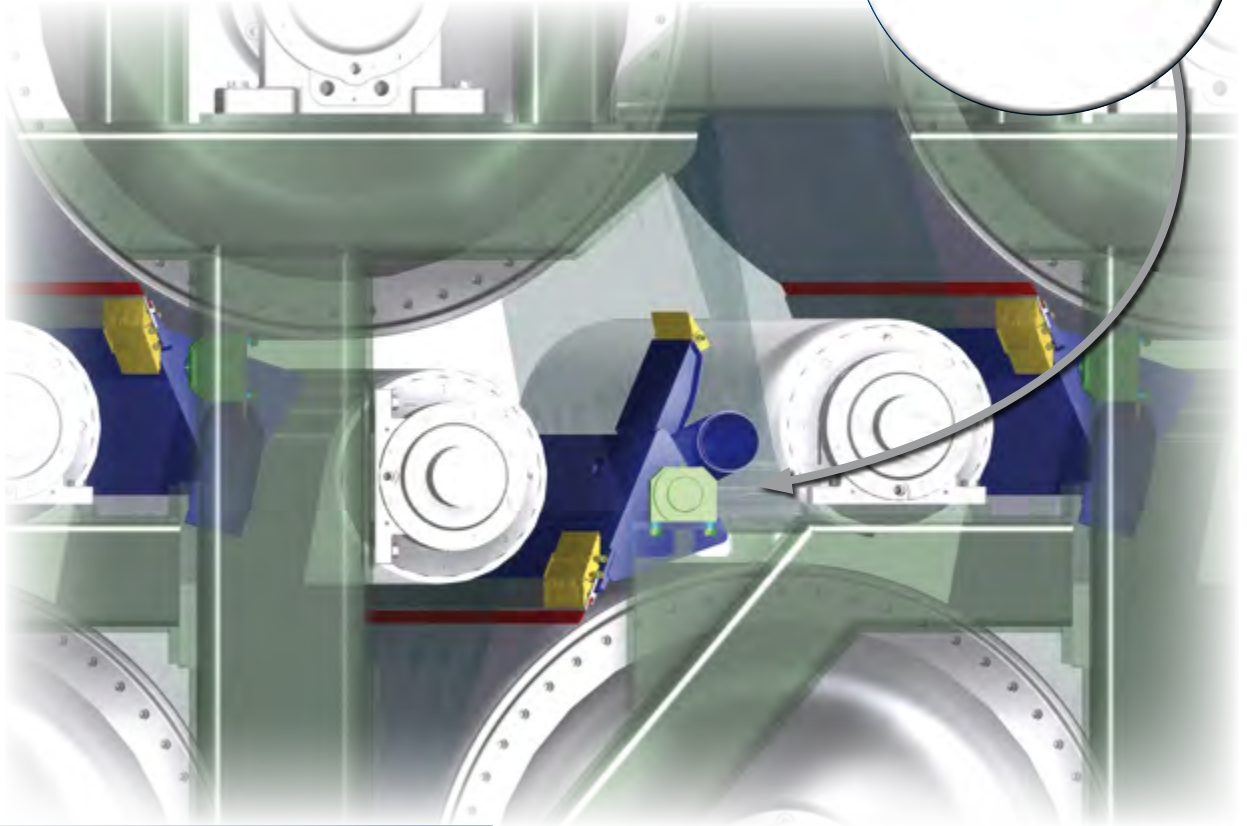

Bonfirm K35

Single and double
doctors for dryer sections
with BONFIFLEX SUPER
holders



Bonfiflex Super

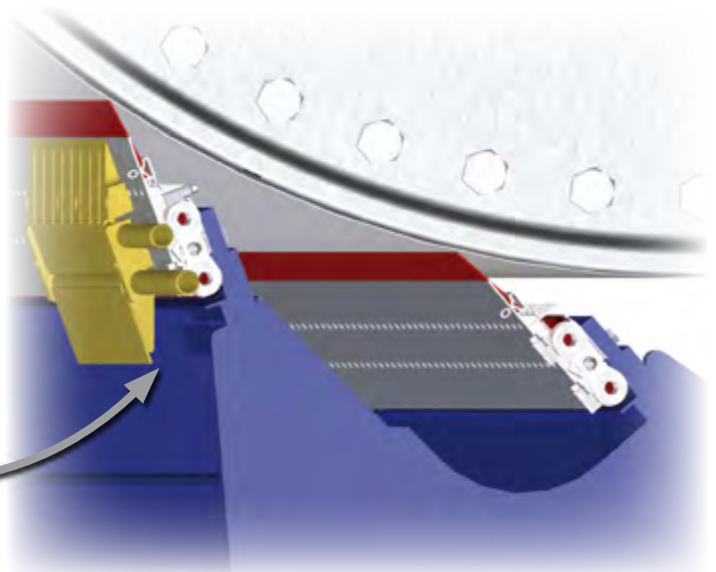

Complete doctor assemblies for calenders

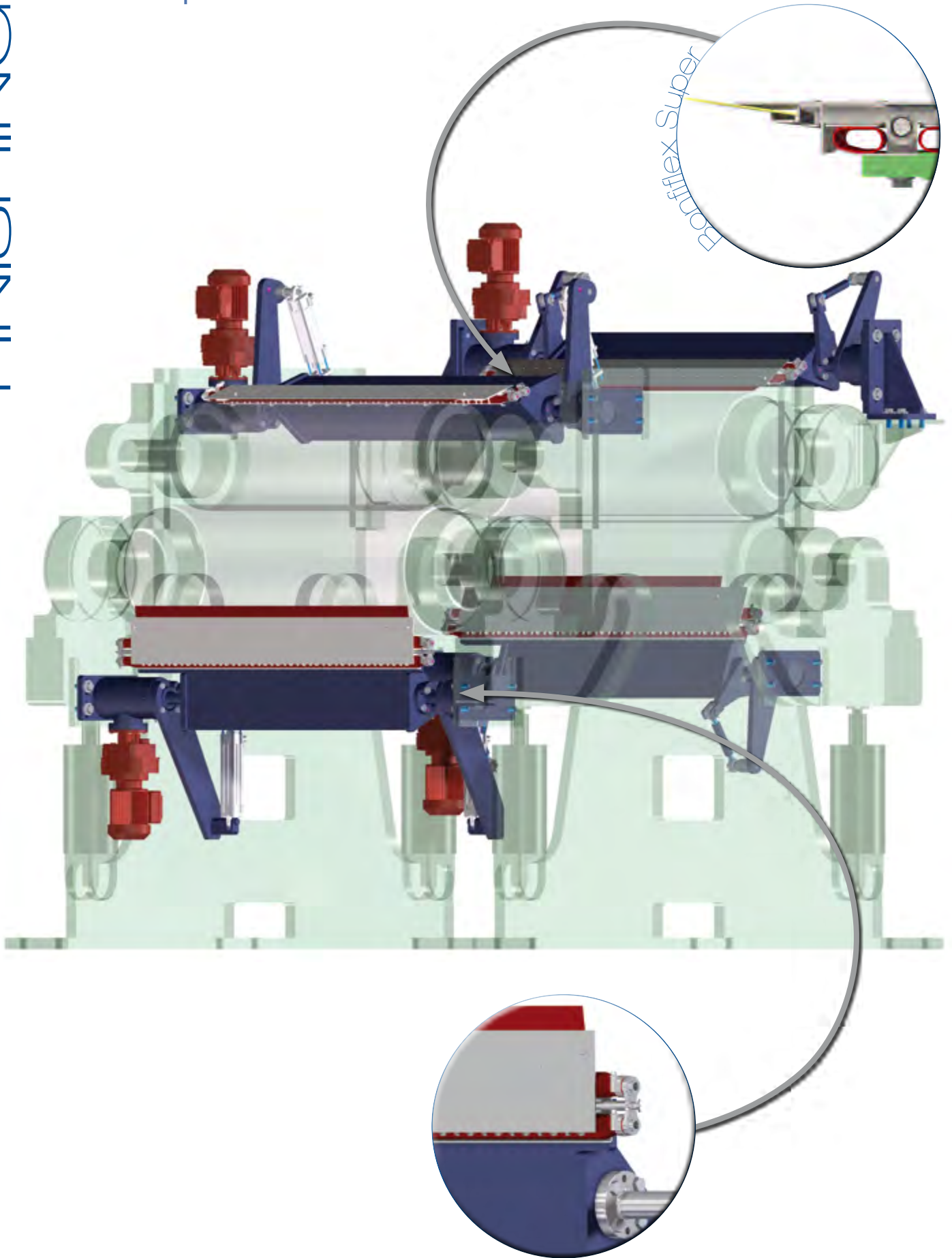

Bearings

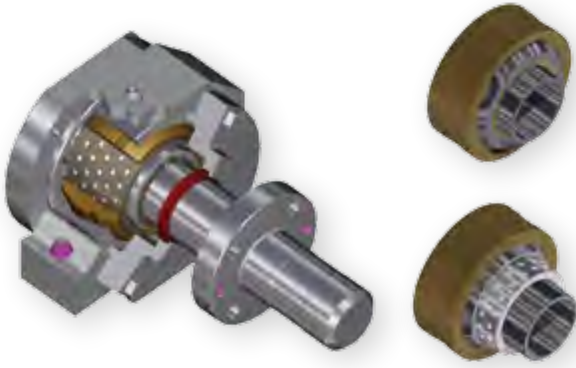

Oscillators

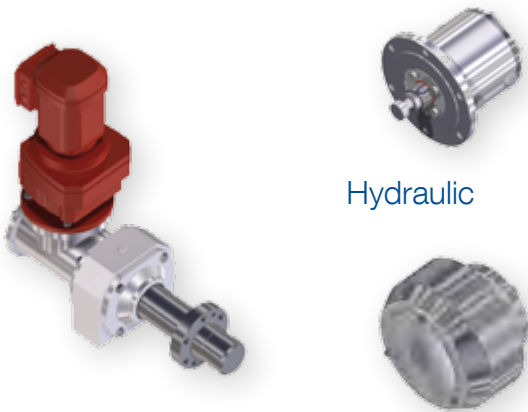

Hydraulic

Electromechanical

Pneumatic

Pressure tubes

BON 70
up to 70°C



BON 140
up to 140°C

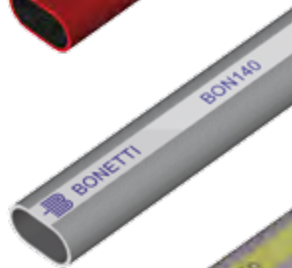

BON 250
up to 250°C

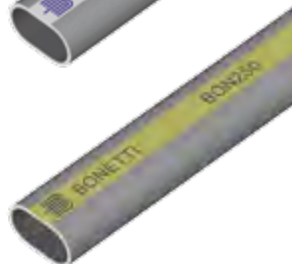

For Bonetti doctor blades please refer to related brochure

Established in 1923 Bonetti has been successfully supplying the pulp and paper industry since more than 50 years. The renowned reliability and quality of coater blades gave rise to the first requests for doctor and creping steel blades in the late 1960's. Synthetic-material doctor blades became available in the 1980's. Challenged by ever-changing doctoring technology, Bonetti has then successfully developed "hi-tech" materials to meet specific Customer needs. In the mid-1990's Doctoring and Creping Systems were a natural addition to the Bonetti Product lines. High-quality Doctor Holders, Systems and Spare Parts, with innovative design



features have since been manufactured and installed throughout the world. To meet worldwide product demands, four (4) new manufacturing facilities were inaugurated in the 1990's and 2000. Sturtevant, WI USA; Hagen, Germany; Cantalupo, Italy; Trois-Rivieres, QC Canada; now complement world headquarters in Lainate, near Milan in Italy. Bonetti's success has always been based on a timely response to the needs and demands of the markets it serves. For more than 50 years, and now in the third generation of family ownership, Bonetti has been and will continue to be a global partner of paper mills and paper-machine manufacturers worldwide.

www.bonetti.com

ITALY

BONETTI S.p.A.
C.so Europa, 23
20020 Lainate (MI) - Italy
Phone +39 02 935 741
Fax +39 02 937 1154
bonetti@bonetti.it

ITALY

BONETTI S.p.A.
Via Fratelli Cervi, 53
20023 Cantalupo di Cerro Maggiore (MI) - Italy
Phone +39 0331 534 707
Fax +39 0331 535 183
bonetti@bonetti.it

GERMANY

BONETTI GmbH
Werkzeugstrasse 28
58093 Hagen - Germany
Phone +49 2331 950 850
Fax +49 2331 950 870
info@bonetti.com

U.S.A.

BONETTI CO., Inc.
14100 West Grandview Parkway
Sturtevant, WI 53177 - U.S.A
Phone +001 262 886 4400
Fax +001 262 886 6300
bonetti.steel@bonetti.com

CANADA

BONETTI CANADA Inc.
101, Place Jourdain Trois-Rivières
Québec, G8W 2H3 - Canada
Phone +001 819 694 2322
Fax +001 819 694 9563
bonetti.canada@bonetti.com

CHINA

BONETTI China
Room 1205 No. 798 ZhaoJiaBang Rd.
200030 Shanghai
Phone +86 21 54657189
Fax +86 21 64453191
china@bonetti.com